

WÖHLER *innovations*



the **World of Brushmaking Machines**

Experience the future!

Join the WÖHLER worlds of
brushmaking machines at



April 27 - 29 2016
MESSE FREIBURG



Visit us at the Interbrush 2016 ...

The **Interbrush** – the world's largest brush sector trade fair – will be held from **27 to 29 April 2016** in Freiburg. Visit Wohler's world of brushmaking machines and experience the absolute highlights in automatic brush production on a stand of over 500 m².

Experience the future!

Join the WÖHLER worlds of
brushmaking machines at

**inter
brush**

Hall 3 | Stand 3.2.8

April 27 - 29 2016
MESSE FREIBURG



ENTRANCE



<http://bt.woehler.com>

the World of **Twisted Brush** Machines

Fully automatic twisted brush machine **TIM 4**

Four core wires and double plane fill.
Direct trimming on the machine.
Brush diameter from 0.24" to 2.40" (6 - 60 mm).

Features

- 2 or 4 core wires
- high density
- integrated trimming station
direct finishing in diameter on the machine
- minimal fill material loss
- material feeding from hank or coil



Fully automatic twisted miniature brush machine **MTI 950**

Blunt front eyelet.
Loseless production – no trimming needed.
brush diameter from 0.032" to 0.79" (0.8 - 20 mm).

Features

- single run production without trimming
- fill materials abrasive, wire, synthetic
- fast fill material exchange
- covered twisting wire possible
- freely programmable twisting cycle



the World of **Strip and Roll Brush** Machines

Strip brush machine **SBM Basic**

Large flexibility – easy handling

Features

- high flexibility – fast product change
- new products – quick and fast set up
- fill material picker for natural, synthetic and abrasive
- sufficient space for hand feeding
- profile sizes from 0.06" (1.5 mm) to 0.32" (8.0 mm)
- production speed up to 16.4 ft/min (5 m/min)

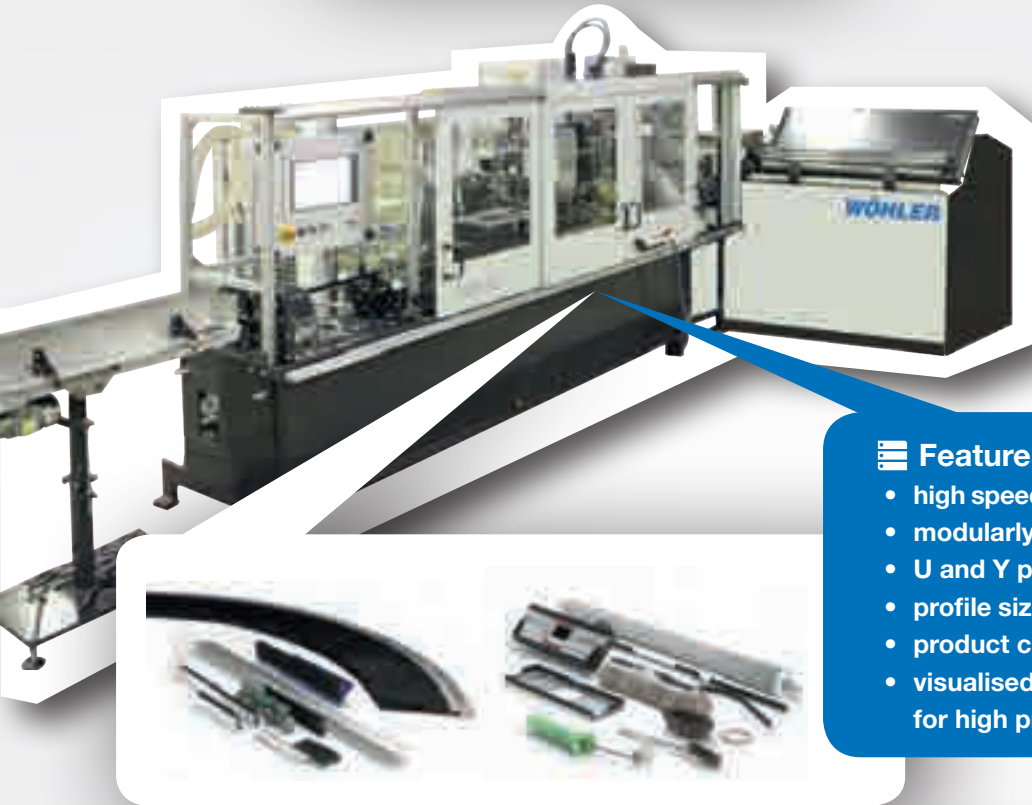
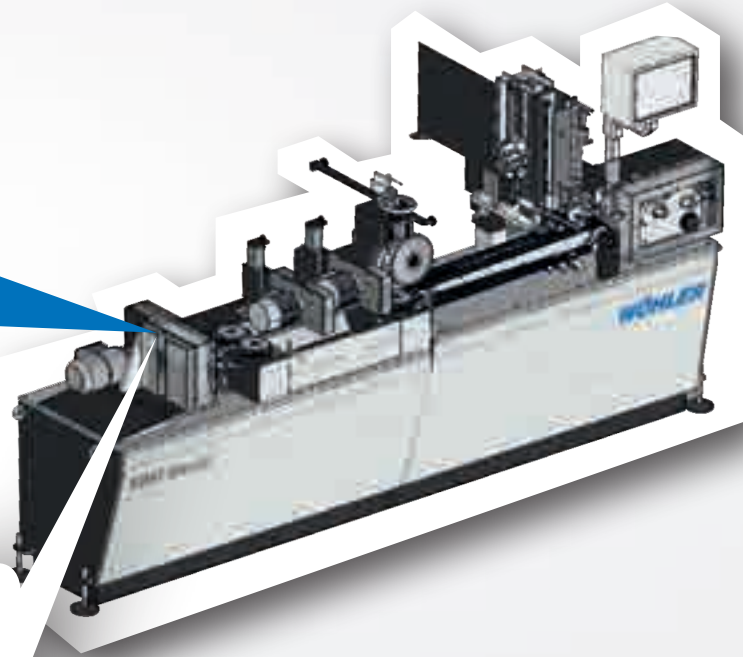

Strip brush machine **SBM 92**

Strip brush production with unbeatable speed and quality.

Features

- high speed production with up to 130 ft (40 m/min)
- modularly upgradable for new products
- U and Y profiles
- profile sizes from 0.06" (1.5 mm) to 0.32" (8.0 mm)
- product change – quick and easy
- visualised fill density and height control for high process reliability



the World of **Power Brush** Machines

Fully automatic twist knot brush machine **ZVA 320**

**Twist knot brushes ready for installation.
Unique new knot types.**

Feature

- punching integrated
- disk changing under 1 second
- enhanced output up to 130%
- up to 30 knots/min.
- outer brush diameter up to 12.6" (320 mm)
- integrated spining-station for perfect alignment and fewer steps before mounting
- knot shape freely programmable in three sections



Highlight at the Interbrush 2016

Fully automatic twist knot machine **ZVA 322**

High output twist knot machine

Features

- outer brush diameter up to 12.6" (320 mm)
- up to 200% enhanced output



the World of **brushtrimming** Machines

Trimming of wheel and roll brushes **FVT-W**

Fully automatic operation cycle for minimum start-up times on product changeover

Features

- fast product exchange
- rapid brush changing in production cycle
- start-up program for diameter control
- easy cleaning
- durable guide systems
- brush holder for rollers and segments
- 15,7" (400 mm) diameter and 29.5" (750 mm) length
- CNC contour cut (optional)

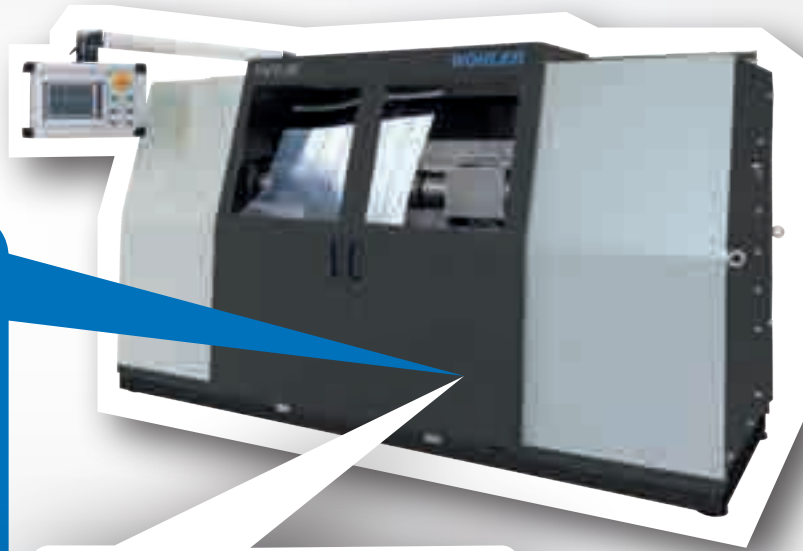

Trimming of cup, wheel and end brushes **FVT 1000**

Economically trimming
Highest safety
0 up to 90° angle cuts possible

Features

- high economic efficiency
- easy cleaning
- cup, wheel and end brushes
- rapid clamping system for brush insertion



the World of **crimping, cutting and bundling** Machines

Bundle cutters

BC 1200 M, BC 1200, BC 1200 NC

From manual to NC-controlled

Highest cutting accuracy

Sorting of bundle remnants (optional)

Sorting of initial clean cuts (optional)

Features (BC 1200 NC)

- cutting power of up to 70 cuts/min.
- precise cuts +/- 0.02" (0.5 mm)
- bundle length starting at 0.6" (15 mm)
- extremely high cutting blade life
- low bundle deformation

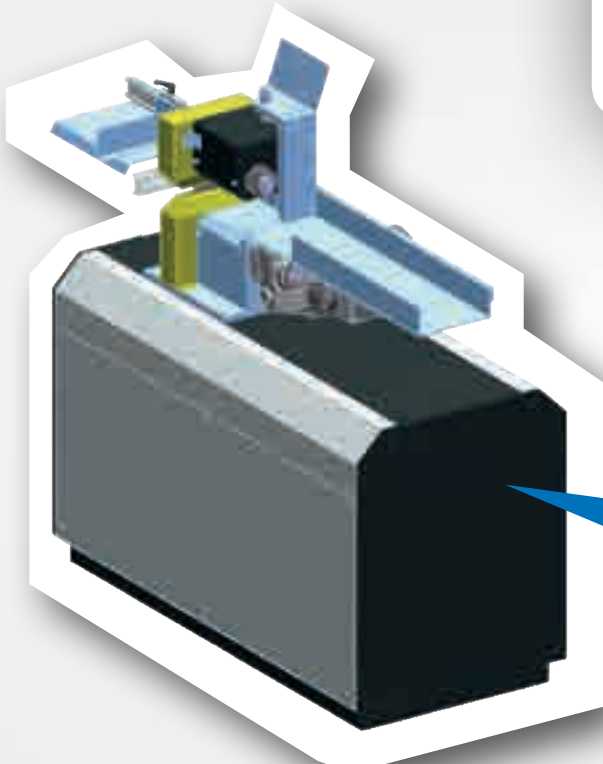

Roller cutter **GR 90**

Great flexibility

Multifunctional applications

Features

- HSS or carbide cutting blades
- various different models and fittings
- round, crimped or flat wire



Machines in **Bad Wünnenberg**

WÖHLER
INNOVATIONS

the World of **Street Sweeper Brush Machines**

Gutter broom machine **GB 20**

Gutter brooms with perfect fit and support
Segments magazine
Drilling station with angle adjustment
Servo tilting table



Features

- maximal bundle effect by adjusting the angle
- improved cleaning action through optimized gutter broom design
- automatic wire and synthetic feed
- highest quality and product diversity



Flat wire roll machine **FWR 250**

Wire flattening, cutting, counting and bundling
Consistent quality – from the first minute

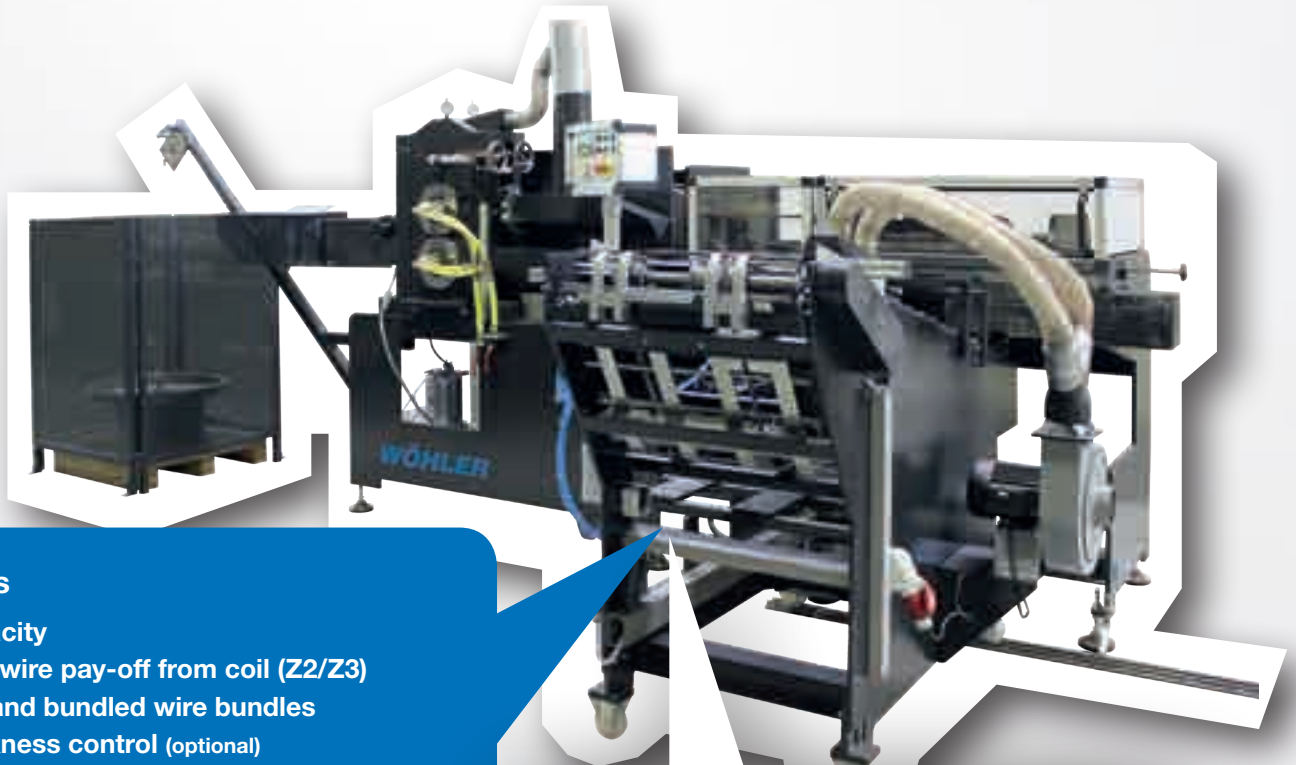

Features

- high capacity
- load-free wire pay-off from coil (Z2/Z3)
- counted and bundled wire bundles
- wire thickness control (optional)
- easy coupling with various assembly machines



the World of **Strip and Roll Brush Machines**

Strip brush machine **MSB 960**

flexible, easily formable strips
for applications with high demands on cleanness and hygiene

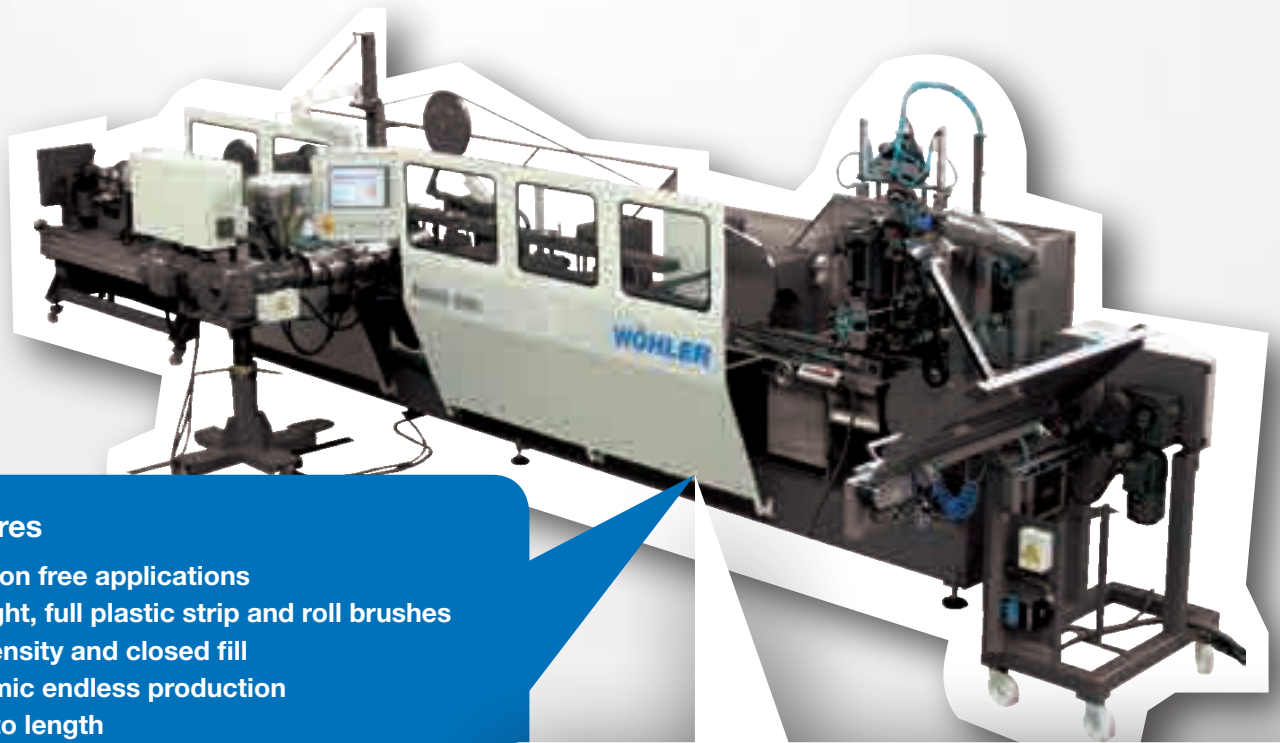

Features

- corrosion free applications
- ultra light, full plastic strip and roll brushes
- high density and closed fill
- economic endless production or cut to length



The world's leader in production systems for...

- **Strip & roll brushes**
- **Flexible strip brushes**
- **Twist knot brushes**
- **Brush & mini segments**
- **Dental & polishing brushes**
- **End brushes**
- **Street sweeper brushes**
- **Twist-in brushes**
- **Tufts & cosmetic brushes**
- **Paint & artist brushes**

Our machinery range also includes...

- **Punching tools**
- **Trimming & cutting equipment**
- **Wire crimping, straightening
& flattening equipment**
- **All plastic parts and brush bodies**
- **Brushing machines**
- **Specialty machines**

theWorldof **Brushmaking Machines**

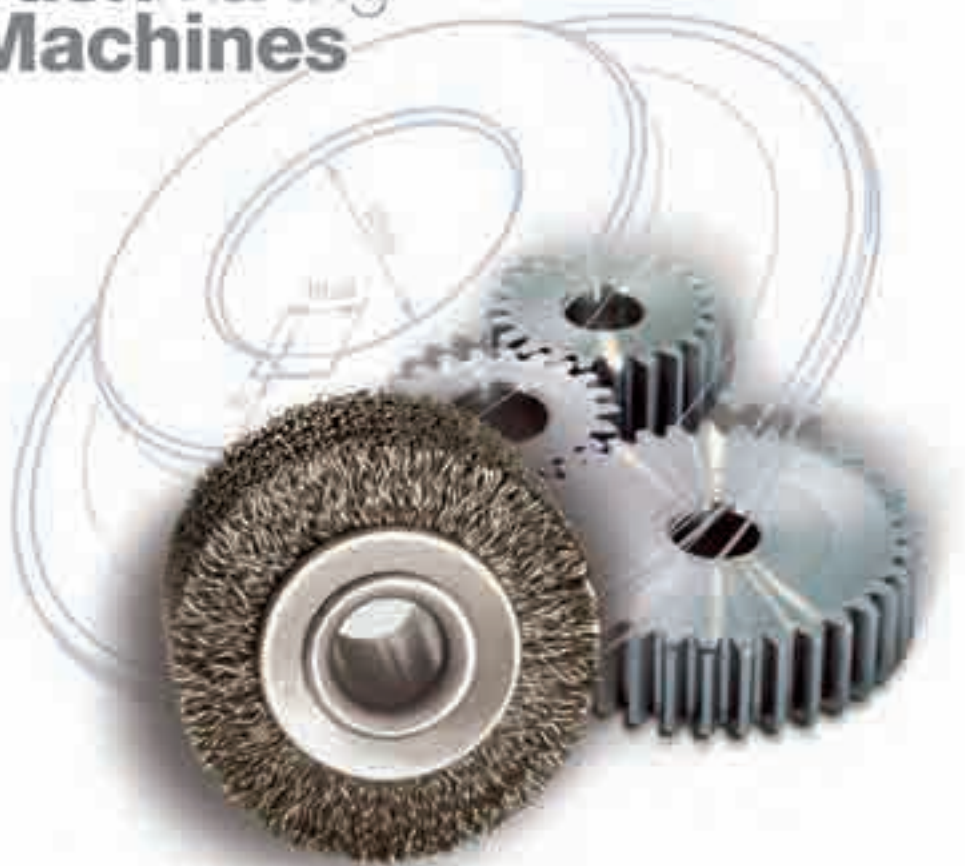

WÖHLER